

# CNPD100-3 SERIES

## Ultra Quiet, Compact Design Exhaust Fans



Canarm's CNPD100-3 fans come complete with high efficiency brushless EC motors. The CNPD100-3 fans are ultra quiet, compact and easily customizable with optional accessories.

### FEATURES

- ETL evaluated and conforms to UL and cUL safety standards.
- Built in toggle switch for CFM (50/80/100) selection
- Totally enclosed brushless EC motor designed to operate continuously
- Detachable 4" polymeric collar which includes a light weight built-in back draft damper
- Elegant yet simple, low profile grille.

### ACCESSORIES

- LED light grille
- Ceiling radiation damper

### DIMENSIONS

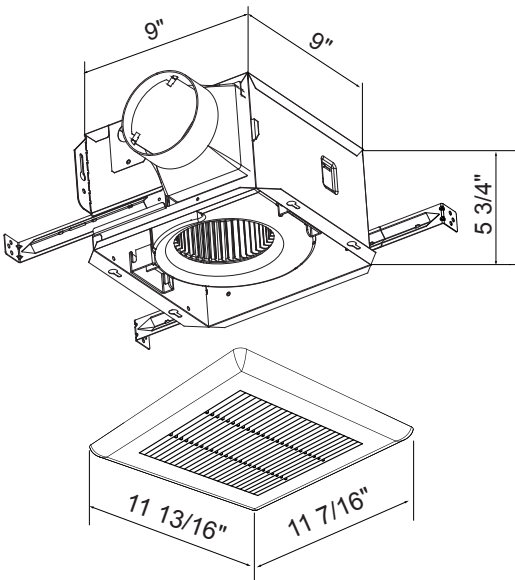

### SWITCH

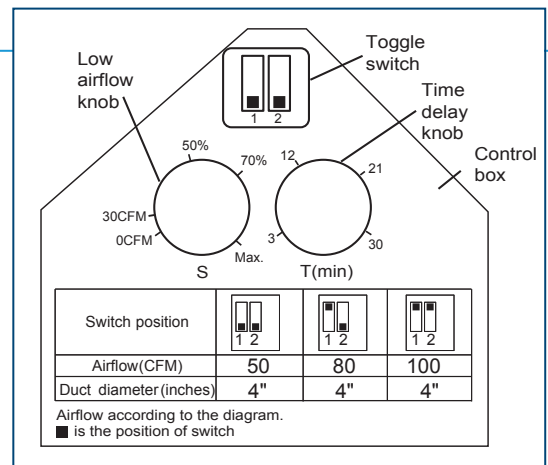

### PERFORMANCE SPECIFICATIONS

MODEL	FOR BATHROOM SIZE UP TO	STATIC PRESSURE (IN W.G.)	CFM	SONES	WATTS	POWER (V/Hz)	DUCT DIAMETER
CNPD100-3	45 FT <sup>2</sup>	0.1	50	0.3	3.3W	120/60	4"
		0.25	42	0.9			
	75 FT <sup>2</sup>	0.1	80	0.4	5W	120/60	4"
		0.25	62	0.8			
	95 FT <sup>2</sup>	0.1	100	0.7	8W	120/60	4"
		0.25	81	1			

### FAN CURVES

