

CESD100-3 SERIES

Ultra Quiet, Slimline Design Exhaust Fans



Canarm's CESD100-3 fans come complete with high performance two speed brushless EC motors. The CESD100-3 fans are ultra quiet, slimline and low profile.

FEATURES

- Ultra quiet slimline design.
- Two speed totally enclosed brushless EC motor designed to operate continuously.
- High performance and efficiency.
- Rugged 26 GA galvanized steel housing.
- Detachable 4" polymeric collar which includes a light weight built-in back draft damper.
- Elegant yet simple, low profile grille.
- Can be ceiling or wall mounted.

ACCESSORIES

- Light Kit
- Ceiling Radiation Damper

PERFORMANCE SPECIFICATIONS

MODEL	CFM	STATIC PRESSURE (IN W.G.)	SONES	WATTS	POWER (V/HZ)	DUCT DIAMETER
CESD100-3	50	0.1	0.6	12	120/60	4"
		0.25	N/A			
	80	0.1	1	12	120/60	4"
		0.25	N/A			
	100	0.1	1.5	12	120/60	4"
		0.25	N/A			

DIMENSIONS

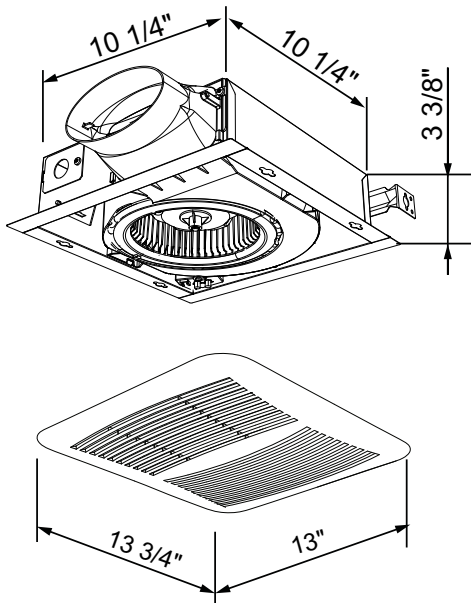

FAN CURVES

